

Front Elevation

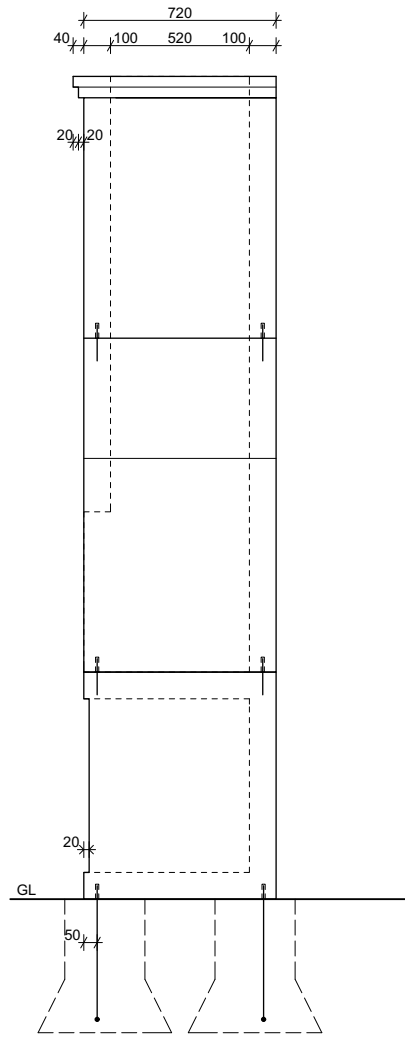

Side Elevation

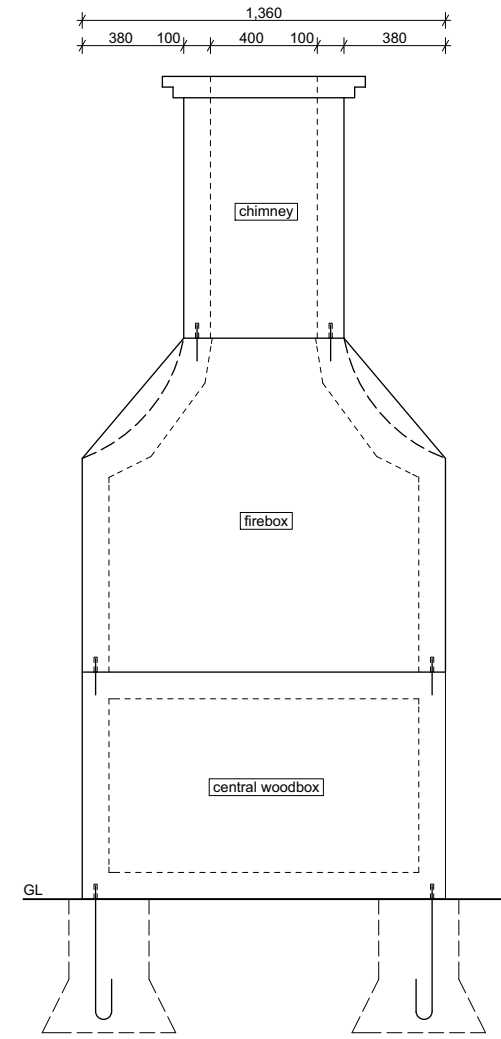

Rear Elevation

Notes:

1. All concrete work shall comply with the requirements of NZS 3109:1997
2. Concrete panels and footings shall be 25MPa
3. Max. slump shall be 100mm unless noted otherwise
4. All panels shall be 100mm thk, unless noted otherwise
5. All panels shall have 668 mesh central and 30mm min cover from edges
6. All inserts shall be TIM10x50g with RT10 galv threaded rod unless noted otherwise
7. All plates, UA's and bolts shall be hot dip galv.

Flare by Gebralter Built - METRO/TUSCANY 2

dwg # PS1-2

28/10/2009

1:20 @ A3